



**INTRODUCING**  
**THE UNISOURCE HEAVY DUTY**  
**ROUND-A-BOUT VI™**  
**15-52 PART SEMI AUTOMATIC BUN DIVIDER/ROUNDER**  
**For Small - Large Buns & Rolls**

***Features:***

- Exclusive - Mechanical rounding operation
- Total weight: 2 lbs. to 8.8 lbs.
- Finished weight: .42 oz - 9.17 oz.
- Heavy Duty Cast iron base w/casters (easy to store)
- S/S cutting knives with adjustable pressure
- Aluminum alloy/teflon coated dividing disc
- Quiet belt driven operation
- Removable pressing handle
- 2800 pieces per hour production capability
- Adjustable weight bar
- Easy to clean dividing disc (Dual-direction hinged head)
- Includes 3 sanitary moulding plates
- Power cord (no plug)
- CE approved . Conforms to UL and NSF standards
- One year parts/labor warranty
- 24/7 nationwide support

***Accessories:***

- Additional moulding plates



**ROUND-A-BOUT IV™**  
**SEMI-AUTOMATIC DIVIDER/ROUNDER**  
**Heavy Duty Cast Iron Base Built to Last with**  
**Electric-Mechanical Rounding Operation**  
**Model UNI-SDR-15-52**



Follow the Leader™

**INTRODUCING**  
**THE UNISOURCE HEAVY DUTY**  
**ROUND-A-BOUT IV™**  
**15-52 PART SEMI AUTOMATIC BUN DIVIDER/ROUNDER**

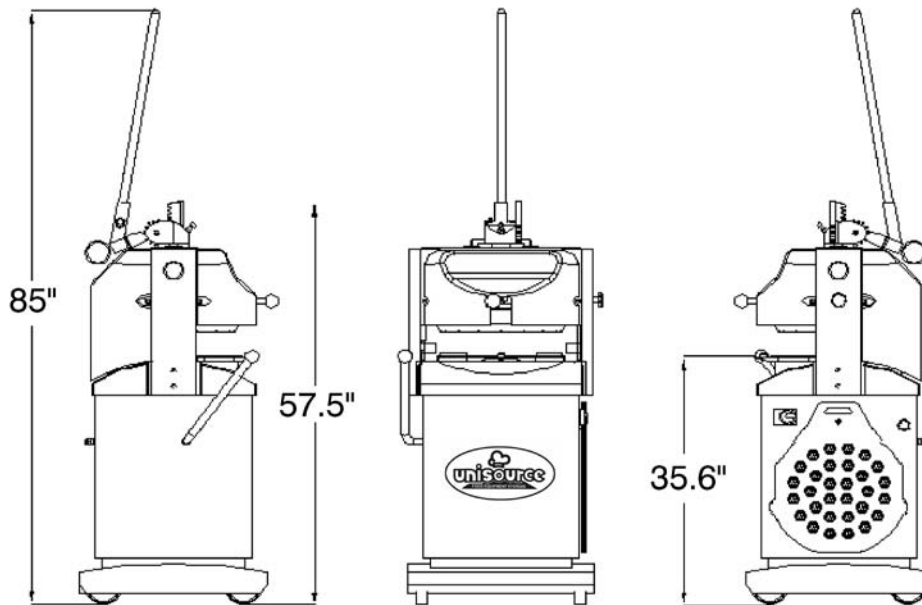

Model	Divisions	Weight Ranges	Dough Capacity (lbs)
UNI-SDRS15	15	3.5 - 9.17 oz.	8.8 lbs.
UNI-SDR-S22	22	1.8-6.5 oz.	8.8 lbs.
UNI-SDR-S30	30	1.4-4.8 oz.	8.8 lbs.
UNI-SDR-S305	30	.88-3.2 oz.	5.9 lbs.
UNI-SDR-S36	36	1.2-3.9 oz.	4.5 lbs.
UNI-SDR-S52	52	.42-1.2 oz.	4.5 lbs.
Model	Description	Divisions	
D	Plate	15, 22, 30, 30S, 36, 52	

**Technical Data**

**Electrical**

**220/60/3 @ 3.2 amps 1.3 kw**

Direct Phone & Service: (516) 527-3309 • (888) 443-7014 • info@unisourcefoodequipment.com • unisourcefoodequipment.com  
 170 Wilbur Place, Suite 300, Bohemia, New York, 11716