



Bakery Aid™

Innovation

By Unisource

ENERGY SAVING
"SLEEP MODE"
TECHNOLOGY

NOW AVAILABLE!
NEW COMPACT
MODELS

INTRODUCING DONUTMATE PLANETARY MIXER

Bakery Aid's gear driven commercial planetary mixers are perfect for any small bakery, restaurant, deli and more. Their heavy duty construction and powerful motor will easily handle any type of mixing task needed with ease. Three fixed speeds and its direct drive 100% gear driven transmission allow the mixers to maintain a consistent mixing speed no matter how much product is in the mixing bowl.

Comes complete with a stainless steel mixing bowl, wire whisk, dough hook and flat beater attachments. The UNI-BAM-20 and UNI-BAM-30 mixers also have a #12 hub for meat grinding attachments. 120V. 5' long power cord with a NEMA 5-15 plug. This unit is ETL Listed and ETL Sanitation and backed by Bakery Aid's 1 year replace or repair warranty.

Operation

- Powerful motors
- Direct drive 100% gear driven transmission for consistent mixing speed
- Three fixed mixing speeds with easy shift
- Push button On/Off switch
- 60 minute timer

Construction

- Heavy duty construction
- Stainless steel wire safety guard around bowl
- Stainless steel bowl clamps hold mixing bowl securely in place during operation
- Rubber inserts on feet for stability

Attachments

- Includes wire whisk, dough hook and flat beater
- Stainless steel mixing bowl
- UNI-BAM-20 and UNI-BAM-30 feature a #12 hub for meat grinding attachments

Electrical

- 120V
- 5' power cord with NEMA 5-15 plug
- Single phase electrical rating



**UNI-BAM-20
Shown**



Bakery Aid[™] Innovation

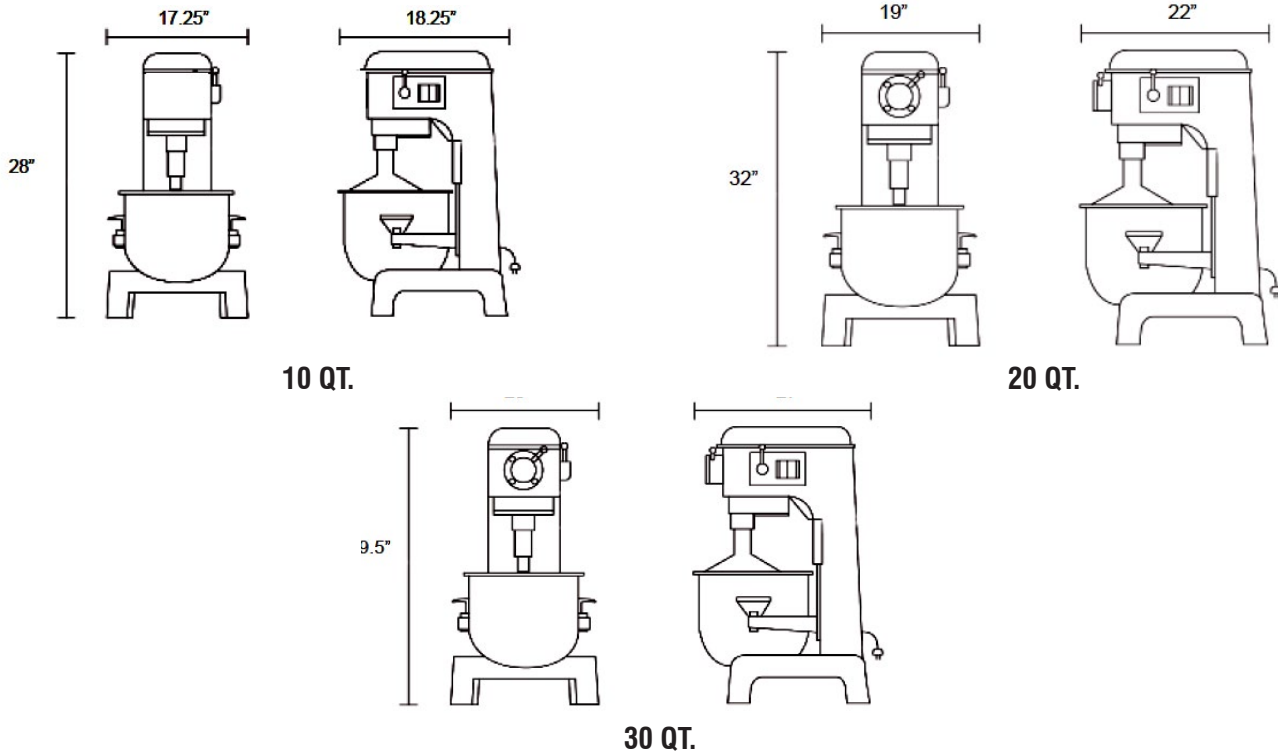

Specifications

Item Number	Description	Volts	Wattage	Amps	Horsepower	NEMA Plug
UNI_BAM-10	Planetary Mixer 10 Qt.	120V	600W	5	0.75 HP	5-15P
UNI_BAM-20	Planetary Mixer 20 Qt.	120V	1100W	9	1.5 HP	5-15P
UNI_BAM-30	Planetary Mixer 30 Qt.	120V	1800W	15	2.4 HP	5-15P

Item Number	Dimension	Speeds	RPMs	Hub Attachment	Timer
UNI_BAM-10	17.25"W x 18.25"D x 28"H	Three	113/184/341	N/A	N/A
UNI_BAM-20	19"W x 22"D x 32"H	Three	108/199/382	#12	0-60 minutes
UNI_BAM30	23"W x 27"D x 39.5"H	Three	84/151/270	#12	0-60 minutes

Shipping Info

Item Number	Box Dimensions	Gross Weight	Net Weight
UNI_BAM-10	21.25"W x 19"D x 28"H	157 lbs	125 lbs
UNI_BAM20	24.75"W x 22.25"D x 34.25"H	250 lbs	205 lbs
UNI_BAM-30	28"W x 25.25"D x 44.5"H	394 lbs	345 lbs

Phone: (888) 443-8782 • Fax: (516) 681-0845 • email: info@unisourcefoodequipment.com • www.unisourcefoodequipment.com
 1505 Lincoln Ave, Holbrook NY 11741

BAKERY AID INNOVATION™ is constantly engaged in a program of improving our products. Therefore, we reserve the right to change specifications without prior notice.
 © BAKERY AID INNOVATION™™ is a Trademark of Unisource Food equipment, FEB 2017