

**NEW!**  
**Save Labor  
 & Time!**

**Removes  
 Carbon  
 Safely!**

## **INTRODUCING THE UNISOURCE DIP TANK 6000™**

### **Fully Automatic Mobile Dip Cleaning Decarbonizer System**

Revolutionary system that cleans cookware without scrubbing for just pennies per item. It is safe, easy to use, and will dramatically improve kitchen appearance. In addition, it reduces labor hours, increases employee morale and uses a 100% bio-degradable solution!

Exclusive Uni-Sonic Technology produces high oscillating air pressure bubbles which removes all kinds of dirt & carbon.

- Bakery Pans
- Vent-a-hood filters
- Stainless steel items
- Plastic and glass pitchers
- Aluminum items
- Rotating pizza oven racks
- Burners and burner plates
- Trash cans
- Charcoal pit grates
- Broiler racks
- Light covers
- Rubber mats
- Coffee cups and porcelain bake ware
- Fryer baskets
- Grease filters



**THE UNISOURCE DIP TANK 6000  
 MOBILE DIP CLEANING SYSTEM**

Fully automatic basket moves up & down to load and unload pans easily.

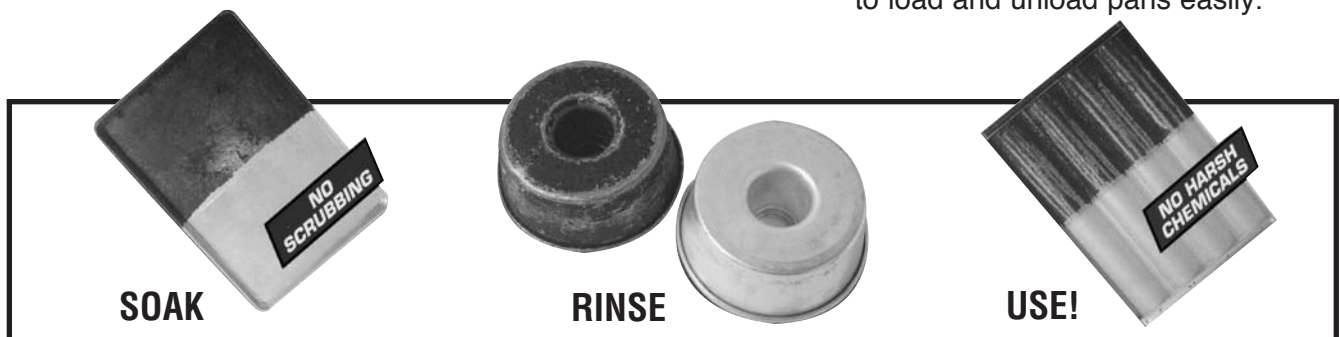

**Is there any other process as safe and convenient in the market place today? The answer is NO!**

- Fast and effective removal of carbon
- Safe operation with up and down basket movement for easy loading & unloading.
- Reduces wash time and water consumption.

**Saves Money!**

Labor hours that range from 15 to 60 per month can be drastically reduced because scrubbing is no longer necessary. Just dip and rinse.

**Safe**

- The Dip Tank is 100% bio-degradable with pH level of 11.5.
- Unit has been certified as USDA "A1" for safe use on all food contact surfaces.
- Department of Transportation regulations do not require any hazardous property warning labels on the containers.
- Skin and eye contact with the diluted solution is equal

to that of soap; which can be rinsed away with water.

- The Dip Tank has no moving parts thus eliminating the chance of injury.

**Labor Friendly**

- Employee moral is increased because the tedious scrubbing process is eliminated.
- Items are easily lowered into the Dip Tank and when the process is complete they are simply pulled out, rinsed and ready to use.

**One Year Parts and Labor Warranty**

The uncomplicated nature of the Dip Tank makes component problems highly unlikely and inexpensive.

**Its dimensions make the Dip Tank unobtrusive**

49" long - 31" wide - 81" high Model 6000.

75" long - 40" wide - 81" high Model 7000.

304 Stainless Steel Construction.

Patent process. Unisource Solution can only be used with this system.

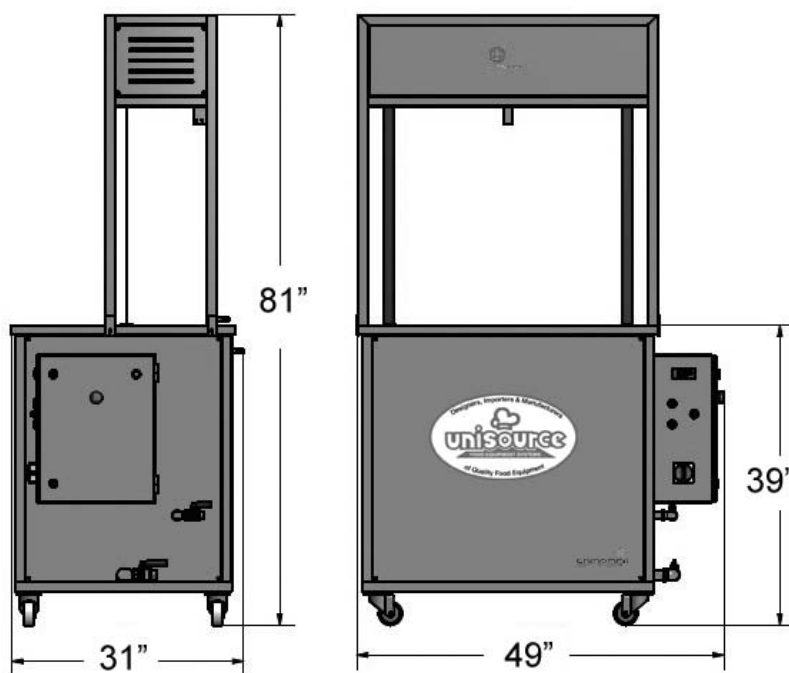

220V/60/1 Phase  
80 Gal. Capacity Bottom Drain, NSF, UL. Shipping Weight 500 lbs.  
3/4" Drain & Water Supply

Direct Phone & Service: (516) 527-3309 • (888) 443-7014 • info@unisourcefoodequipment.com • unisourcefoodequipment.com  
170 Wilbur Place, Suite 300, Bohemia, New York, 11716