



# Chefmerica™

**1104  
DISHES  
PER HOUR!**

## INTRODUCING HIGH PERFORMANCE LARGE CAPACITY DISHWASHER

The **Chefmerica™** Standalone Dishwasher is perfect for high volume Restaurants, Cafes, Espresso Bars, Sub Shops, Ice Cream Parlors & Food Courts. It's powerful washing arms and energy efficient technology, put it far ahead of the competition. Great for Glassware, Utensils & Dishes with low water usage. Washing capacity is 69 Racks or 1104 plates per hour.

### EXCLUSIVE FEATURES

- Stainless steel body including washing and boiler tank
- Monoblock washing tank with round corners - Hygenic
- Suitable for corners and in-line installations
- Adjustable feet for height optimization
- Electrical components and cabling according to international standards and safety regulations
- Non-returned check valve system
- Operating temperatures:  
Washing temperature : 158 °F ( 70 °C )  
Rinsing temperature : 180 °F ( 82 °C )
- Washing arms both available in stainless steel and reinforced polypropylene
- Door safety switch
- Digital rinsing and washing water temperature display
- 69 racks per hour for OBM 1080 (Rack dimensions 20" x 20")
- 0,75 Gal (2.8 lt ) water consumption per cycle
- 3 selectable washing programmes - cycle 52, 102, 132 seconds
- Easy start-up: Single button for water filling and heating in the boiler tank

### CONSTRUCTION

- Full width interior scrap screens or durable stainless steel
- Closed type pump fan motor protection
- Safety micro-switch on door to interrupt wash pump action
- Lower and upper revolving wash rinse arms made of fiberglass for maximum performance and maintenance
- Independently-operated heating elements alternating between the booster and wash tank.
- Both alternating heating elements serve to reduce overall energy costs by lowering amperage consumption
- Thermostatic regulated control of both wash & rinse water
- Automatic fill and water level regulation of the wash tank
- Individual thermometer gauges for both wash and rinse temperatures
- Vertical integrated control panel; for simple access and technical maintenance
- Door opening 18.11"
- High energy efficiency technology
- 1 year part and labor. 24/7 nationwide service



**UNI-OBM US PLUS 1080**



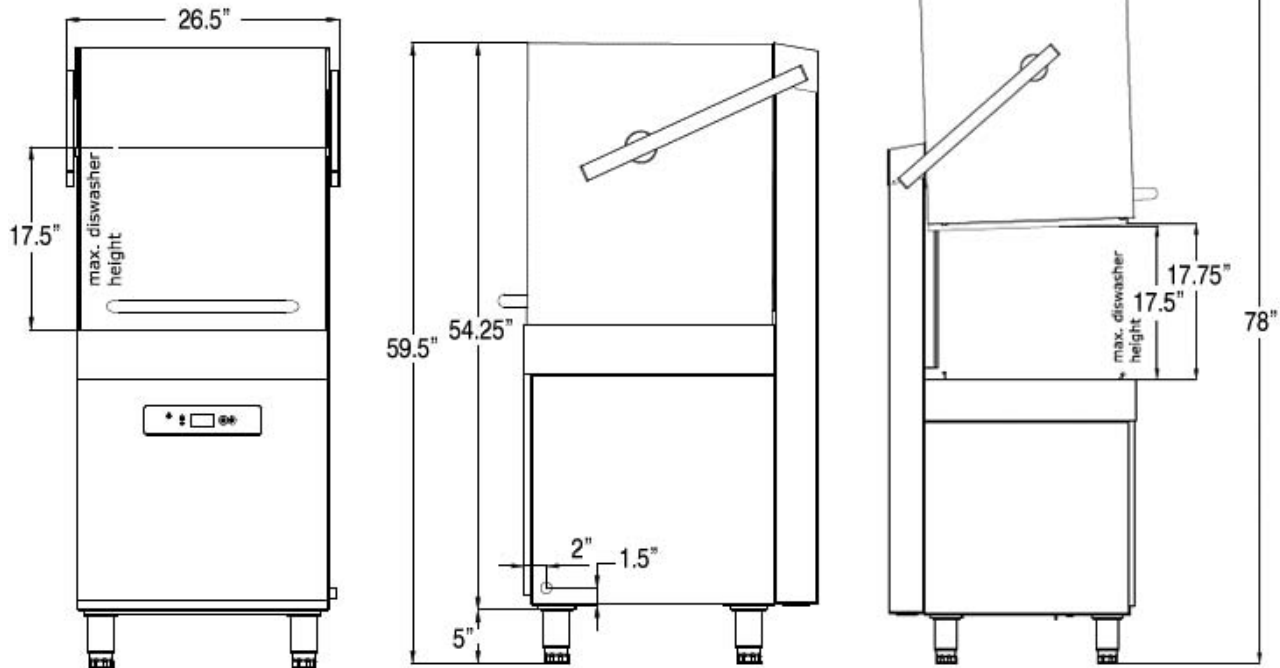

DIMENSIONS (Actual)	
Width	27.5"
Depth	30.9"
Height	59.4"
Weight	275 lbs.

DIMENSIONS (Shipping)	
Width	30"
Depth	35"
Height	66.92"
Weight	185 lbs.

TECHNICAL FEATURES	
Washing Capacity (Plate/hr)	1080
Washing Capacity (Basket/hr)	69
Washing/boiler Tank Capacity	9.73 Gal.
Washing Pump Motor	1.32 HP
Heat Power (Washing/Drying)	1.5 - 3.9 Kw.
Max. Noise (dBA)	85 dBA
Loading Height	18.11"
Booster Element	9 Kw.
Total Voltage	240v/60/3 Phase, 24.3 Amps.
Water Inlet	15-25 PSI
Water Pump Temperature	122° F
Dirty Water Discharge Connection	1 1/4"
Booster Capacity	1.84 Gal
Wash Tank Element	3 Kw.