



Chefmerica™

INTRODUCING HEAVY DUTY 20 QUART PLANETARY MIXER

The **Chefmerica™** Planetary Mixers are highly reliable mixers that let you handle even the most demanding of professional food applications with ease. Its advanced design makes it ideal for mixing every type of dough like Bread, Rolls, Bagels, Pastries, Donuts, and other food products.

CONSTRUCTION:

Our excellent cast technicians use the latest computerized technology with no sharp corners or seams. We offer heavy duty Gear and Belt Driven Transmissions for any kind of dough. Our high and open base helps make it convenient to clean the work area.

We offer a heavy duty gauge, high polished Stainless Steel Safety Guard and a Safety Limit Switch that immediately shuts off power to the operator. A timer is also included. Harden Steel Drive Worm and Bronze Alloy Worm Wheel. Gears shift smoothly and are strong enough for mixing any kinds of heavy dough.

The grinding process for our equipment operates the Gears and Shafts smoothly and without noise. High precision design of the Gears and Shafts assure them long life with easy interchangeability when needed.

TRANSMISSION:

All Transmission Gears & Shifts are made of heat treated special Alloy Steel. Much larger than ordinary similar sized mixers available on the market today. All Shafts are mounted in heavy duty Ball or Roller Bearing.

MOTOR:

Our powerful motors are designed to meet all mixing challenges. Our special cooling fan design gives our motor smooth consistent power that is desirable by all operators.

HUB ATTACHMENTS:

No. 12 (standard size) hub accommodates a variety of attachments for food grinding, shredding, slicing, etc. There is a Bearing and Oil Seal inside to help the attachment move smoothly and protect Oil from leakage.

ACCESSORIES:

All of the tools are precisely fitted to the bowls. The bowls can be easily removed for cleaning.



**UNI-20CM
20 QUART MIXER**

- Three fixed speeds.
- Easy speed shifting.
- 100% gear driven.
- Long life Gear-Box.
- Powerful 120 Volt Motor.
- #12 hub.
- Safety Guard.
- Timer.
- ETL/NSF Approved.
- 1 Year Parts and Labor.
- 24/7 Nationwide Service





Chefmerica™

**INTRODUCING
HEAVY DUTY
20 QUART PLANETARY MIXER**

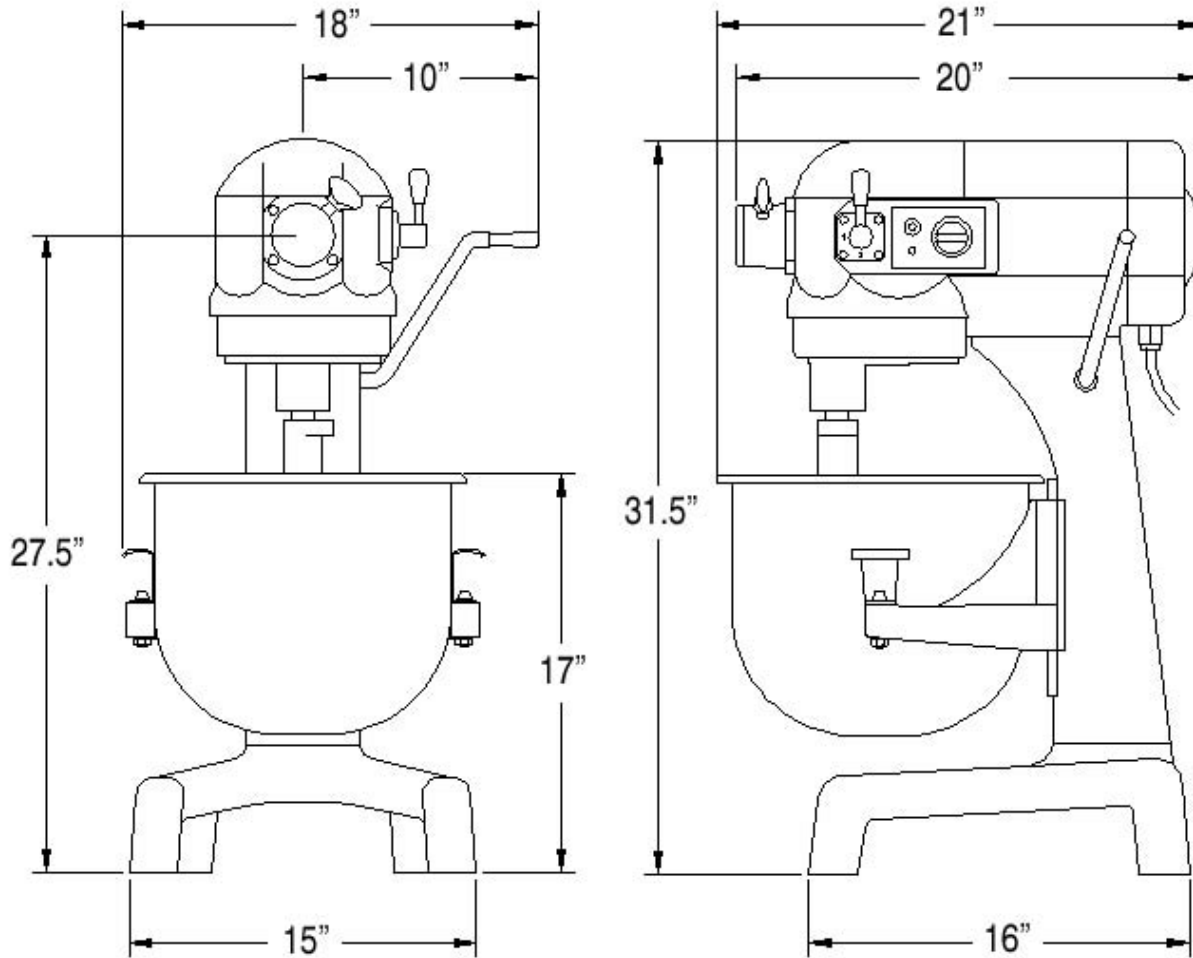

Standard Accessories:

- Spiral Dough Arm.
- 20 Qt. Stainless Steel Bowl: 1Pc.
- Mixing Hook: 1 Pc.
- Flat Beater: 1 Pc.
- Wire Whip: 1 Pc.

Optional Accessories:

- Wire Whip: 1 Pc.
- Vegetable Slicer Attachment: 1 Pc.
- Meat Grinder Attachment: 1 Pc.
- Digital Control Panel: 1 Pc.

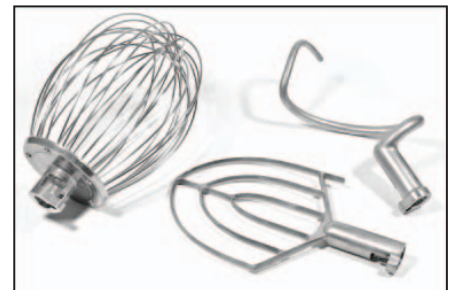

MODEL	BOWL CAPACITY	MOTOR	AGITATOR SPEED (RPM)	15 MIN. TIMER	HUB	SAFETY GUARD	Wt.
UNI-20CM	20 QT.	1/2 HP	139, 259, 473	STD.	STD.	STD.	215 LBS.