

INTRODUCING THE UNISOURCE HEAVY DUTY BAGEL KETTLE™

Unique spun bowl design allows heat Transfer on bowl sides, as well as bottom, for faster boiling and greater efficiency and gas savings of hundreds of dollars annually.

Easy to use heavy duty gas controls for longer life.

Spun bowl design is easier to clean than any other kettle. This design is Bissc Approved and meets nsf construction standards. No other traditional bagel kettle is sanitation approved.

45 Gallon Capacity bowl.

No electric requirements and an improved, aga certified vent system will save hundreds of dollars in construction and installation costs.

Quality, high efficiency burner is adjustable from 80,000 to 180,000 btu's per hour.

Bagel Kettle has been perfected by bagel bakers, for bagel bakers. Under development for over 2 years, it has all the features and refinements needed in today's bagel bakery.

Whether you are making the traditional East Coast bagel or the soft and chewy West Coast bagel, you will boil perfect bagels every time.

For speed, convenience, gas efficiency, and sanitation, there is no comparison. The only fully approved American Gas Association (AGA) and Bakery Sanitation (Bissc) Certified Bagel Kettle available today!



**THE UNISOURCE HEAVY DUTY
45 GALLON CAPACITY BAGEL BOILER**



BAGEL KETTLE HOOD



Follow the Leader™

INTRODUCING THE UNISOURCE HEAVY DUTY BAGEL KETTLE™

Kettle Specifications					
Capacity*	Tank Dimensions		Gas		Flue Outlet
	Inside Diameter	Inside Deep	Connection	BTU/hr.	
45 gal.	29"	16"	3/4"	200,000	8"

*Also available in 25-gallon capacity with 3 ft. square hood

10/13/04



#386-83-E

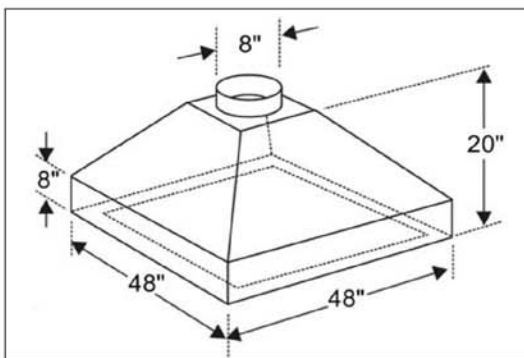
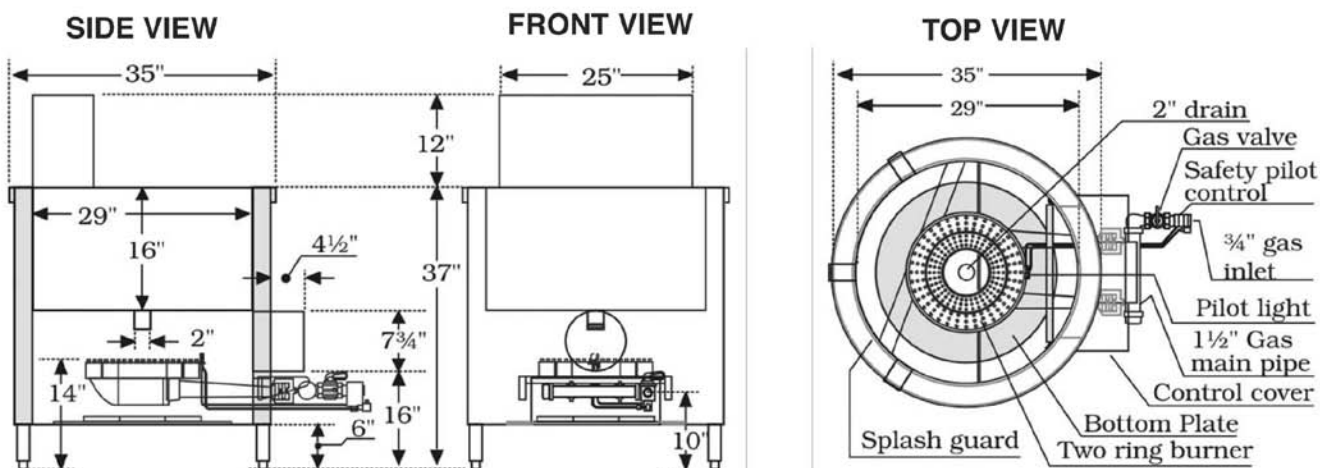

Direct Phone & Service: (516) 527-3309 • (888) 443-7014 • info@unisourcefoodequipment.com • unisourcefoodequipment.com
 170 Wilbur Place, Suite 300, Bohemia, New York, 11716