



Follow the Leader™

CAROUSEL CHECKOUTS

UNI-SBCC SERIES

Introducing the **Unisource Carousel Checkout Series** for Supermarkets, Convenience and Dollar Stores, Discount Drug and Specialty Retail. We offer high quality workmanship and construction that's built to last. Available in Carousel Design. Other models available. We also can custom build any unit to your spec!

STANDARD FEATURES

- Includes Front Transport, Bagging Carousel & Cashier Stand
- Grommet Hole In Cashier Stand for Power Plug
- Cash Shield
- 8" x 21" Carousel Shelf
- 4 Rack Carousel
- Conveyor Drive With Overload Protection
- Plastic Upper & Lower Bumper Guards
- Stainless Steel Protective Corners
- Stainless Steel Deck Surface
- Exterior Colors Available in Black, Gray Or Almond
- Utility Drawer
- Clean Out Tray
- Electronic Access Panel
- Isolated Ground Circuit
- 120 Volts
- Electric Eye
- Endless/Seamless Belts
- Two Order Dividers
- Scan Kit

OPTIONS

- Laminate Deck Surface
- Extra Order Dividers
- 6 Rack Carousel
- Electrical Receptacle For Merchandiser
- Lane Closure Gate
- Cash Stand
- Bagging Well Cut-Out
- Chrome Bag Rack
- Diverter Bar
- Security Mirror
- EFT Holder
- Keyboard Stand With EFT Holder or Keyboard Stand Only
- Monitor/Readout Post
- Top Bag Dispenser For Carousel
- A.D.A. Check Writer
- Extra Bumper Protection

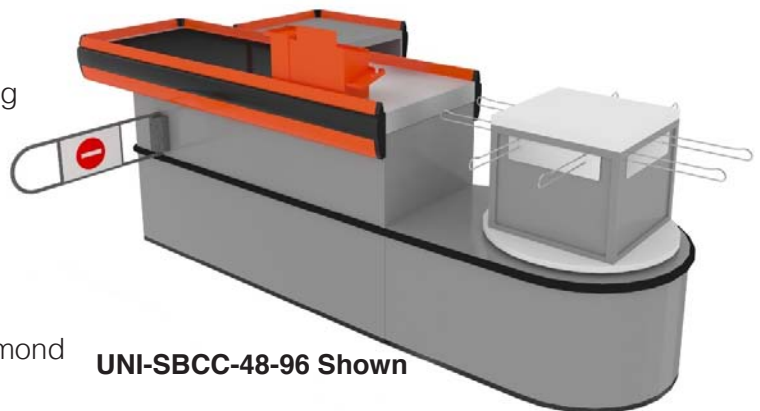

UNI-SBCC-48-96 Shown

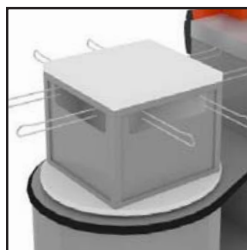
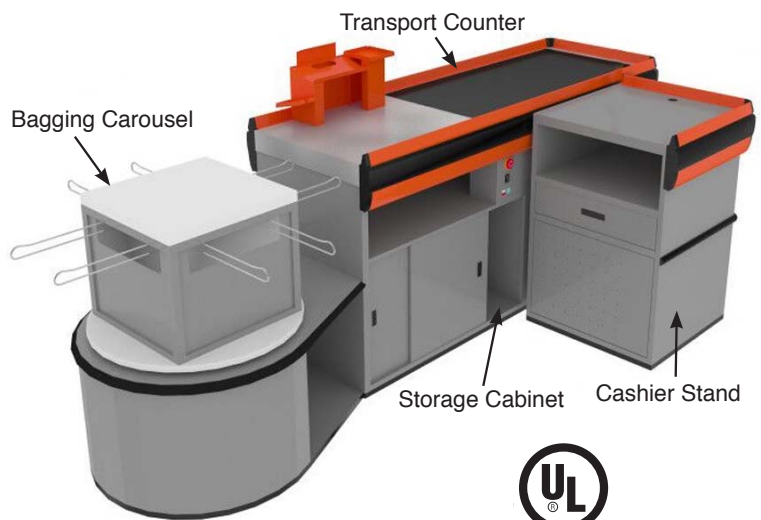

4 Bag Carousel

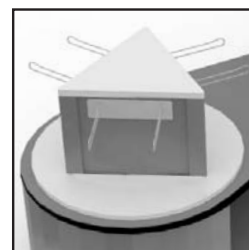

3 Bag Carousel



Storage & Drawer

Direct Phone & Service: (516) 527-3309 • (888) 443-7014 • info@unisourcefoodequipment.com • unisourcefoodequipment.com
170 Wilbur Place, Suite 300, Bohemia, New York, 11716

Follow the Leader™

CAROUSEL CHECKOUTS

UNI-SBCC SERIES

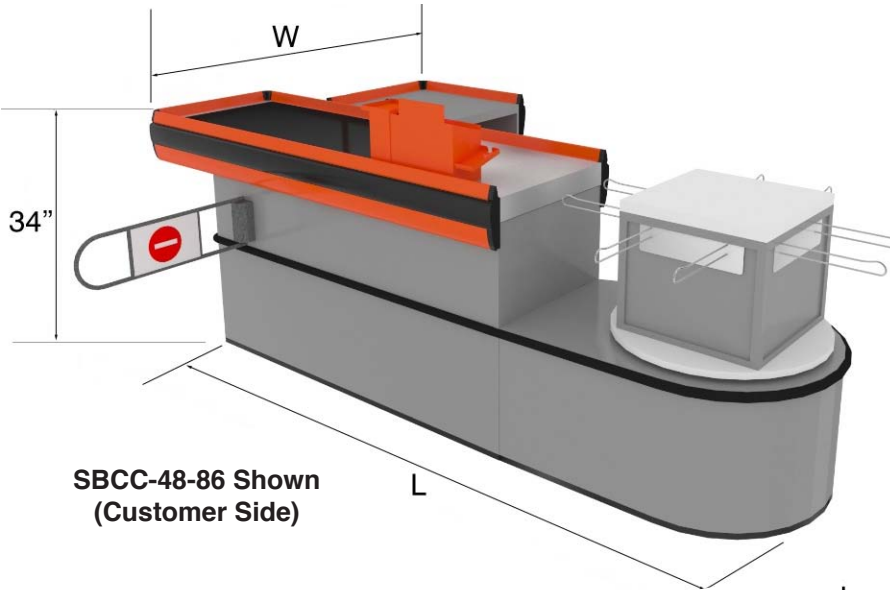

SBCC-48-86 Shown
(Customer Side)

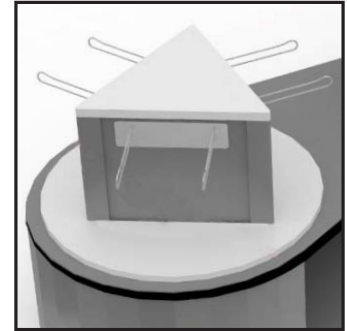

3 Bag Carousel Available
42 Series

- 120 Volts
- 5 Amps
- Hard Wire or Power Cord

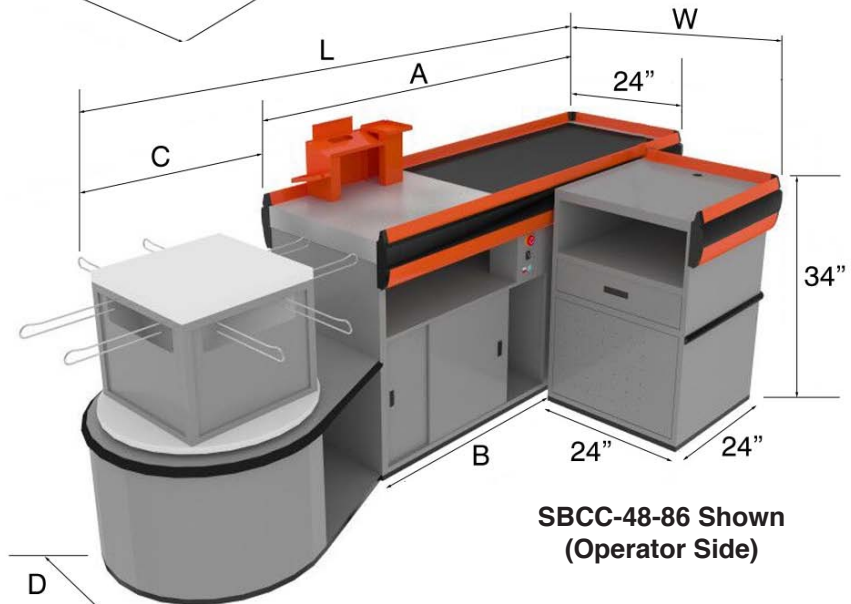

SBCC-48-86 Shown
(Operator Side)

3 Sided Carousel	4 Sided Carousel	Overall Length (L)	Overall Width (W)	Overall Height (H)	Front Transport Length (A)	Front Transport Width	Transport Storage Cabinet L x W (B)	Carousel Cabinet Length (C)		Carousel Cabinet Width (D)		Cashier Stand	Weight (Lbs.)
		-42 -48						-42 -48	-42 -48	-42 -48			
UNI-SBCC-42-90	UNI-SBCC-48-96	90" 96"	48"	34"	48"	24"	18" x 24"	42" 48"	42" 48"	24" x 24"	300 lbs.		
UNI-SBCC-42-102	UNI-SBCC-48-108	102" 108"	48"	34"	60"	24"	24" x 24"	42" 48"	42" 48"	24" x 24"	330 lbs.		
UNI-SBCC-42-114	UNI-SBCC-48-120	114" 120"	48"	34"	72"	24"	36" x 24"	42" 48"	42" 48"	24" x 24"	360 lbs.		
UNI-SBCC-42-126	UNI-SBCC-48-132	126" 132"	48"	34"	84"	24"	48" x 24"	42" 48"	42" 48"	24" x 24"	390 lbs.		
UNI-SBCC-42-138	UNI-SBCC-48-144	138" 144"	48"	34"	96"	24"	60" x 24"	42" 48"	42" 48"	24" x 24"	470 lbs.		

Direct Phone & Service: (516) 527-3309 • (888) 443-7014 • info@unisourcefoodequipment.com • unisourcefoodequipment.com
170 Wilbur Place, Suite 300, Bohemia, New York, 11716