



Follow the Leader™

DOUBLE CHECKOUT WITH SINGLE BELT DRIVES

UNI-DBLCO SERIES

Introducing the **Unisource Double Checkout Series With Single Belt Drives** for Supermarkets, Convenience and Dollar Stores, Discount Drug and Specialty Retail. We offer high quality workmanship & construction that's built to last. Other models available. We also can custom build any unit to your spec!

STANDARD FEATURES

- Includes Two Sets:
 - 2 Front Transports, 2 Bagging Areas
 - & 2 Cashier Stands
- Grommet Hole In Cashier Stand for Power Plug
- Cash Shield
- Outside storage with Shelf
- Conveyor Drives With Overload Protection
- Plastic Upper Bumper Guards
- Stainless Steel Protective Corners
- Stainless Steel Deck Surface
- Many Exterior Colors Available
- Utility Drawer
- Clean Out Tray
- Electronic Access Panel
- Isolated Ground Circuit
- 120 Volts
- Electric Eye
- Endless/Seamless Belts
- Two Order Dividers
- Scan Kit

OPTIONS

- Laminate Deck Surface
- Extra Order Dividers
- Electrical Receptacle For Merchandiser
- Lane Closure Gate
- Cash Stand
- Bagging Well Cut-Out
- Chrome Bag Rack
- Diverter Bar
- Security Mirror
- EFT Holder
- Keyboard Stand With EFT Holder or Keyboard Stand Only
- Monitor/Readout Post
- Top Bag Dispenser For Carousel
- A.D.A. Check Writer
- Extra Bumper Protection
- Many Custom Color Options Available

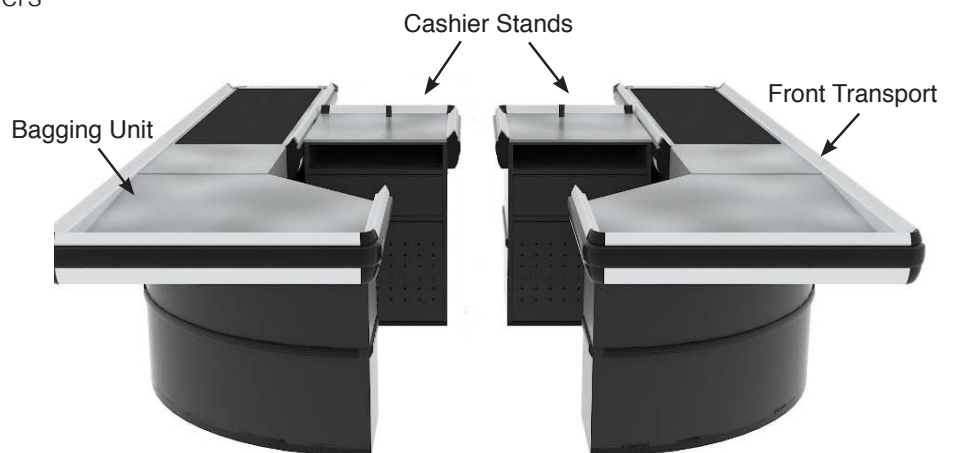

Single Belt Conveyor



Exterior Storage

Direct Phone & Service: (516) 527-3309 • (888) 443-7014 • info@unisourcefoodequipment.com • unisourcefoodequipment.com
170 Wilbur Place, Suite 300, Bohemia, New York, 11716

Follow the Leader™

DOUBLE CHECKOUT WITH SINGLE BELT DRIVES

UNI-DBLCO SERIES

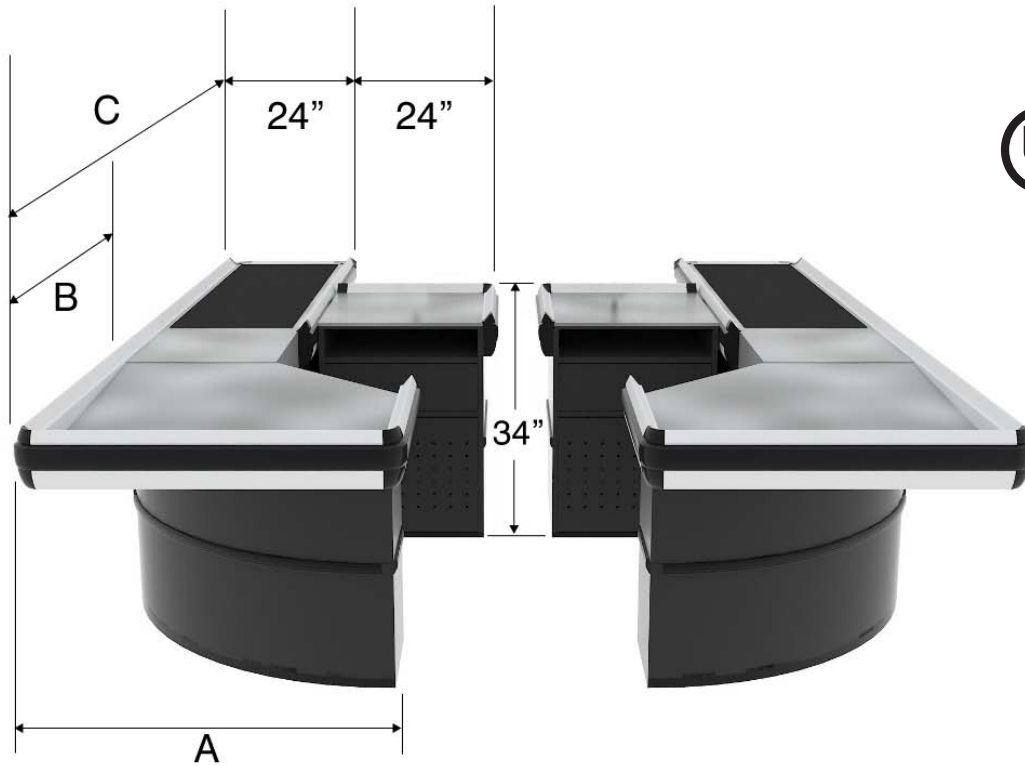

- 120 Volts
- 5 Amps
- Hard Wire or Power Cord

Mix & Match Modular Units To Create The Perfect Checkout

Model	Overall Height All Units	Modular Bagging Unit			Modular Front Transport			Transport Shelves L x W (D)	Cashier Stand	Cashier Stand Wt. (lbs.)
		Bagging Area Width (A)	Bagging Area Length (B)	Bagging Area Wt. (lbs.)	Front Transport Width	Front Transport Length (C)	Front Transport Wt. (lbs.)			
UNI-SB-DBLCO	34"	48" Wide	Select Size:		24" Wide	Select Size:			24" x 24"	77 lbs.
			39"	140 lbs.		48"	160 lbs.	24" x 24"		
			48"	170 lbs.		60"	210 lbs.	36" x 24"		
			56"	200 lbs.		72"	260 lbs.	48" x 24"		
			61"	230 lbs.		84"	310 lbs.	60" x 24"		
69"	260 lbs.	96"	360 lbs.	72" x 24"						

Direct Phone & Service: (516) 527-3309 • (888) 443-7014 • info@unisourcefoodequipment.com • unisourcefoodequipment.com
 170 Wilbur Place, Suite 300, Bohemia, New York, 11716