



HALSTON DESIGNER SERIES

Countertop DRY display case



PRODUCT SPECIFICATION

Model	Doors	Capacity (cu.ft)	Shelves	Cabinet Dimensions (Inches / mm)			Lighting	Voltage	Amps	TEMP	Net Weight (lbs. / kg)
				L	D	H					
ST540D	2	5.54	2	48" 1219	22 2/5" 568	27" 686	YES	110V/60Hz	0.50	Ambient	113 51.5



In Accordance with
AHRI Std 1200

DOE 2017
Energy Efficiency
Compliant

STANDARD FEATURES

- This bakery display case features bright, cool LED lighting that is designed to show off your baked goods! With a proper display, your bakery items can merchandise themselves and increase impulse sales.
- The case also has two chrome plated wire interior shelves that you can adjust depending on the items you want to display. In total, this model has a capacity of 5.54 cu. ft.
- The curved front glass provides an unobstructed view of your food while the side glass panels and the rear glass access doors ensure that customers can see the case's contents from any angle.
- ETL approved (conforms to UL-471&NSF-7)
- DOE 2017, Energy efficient compliant

Plan view

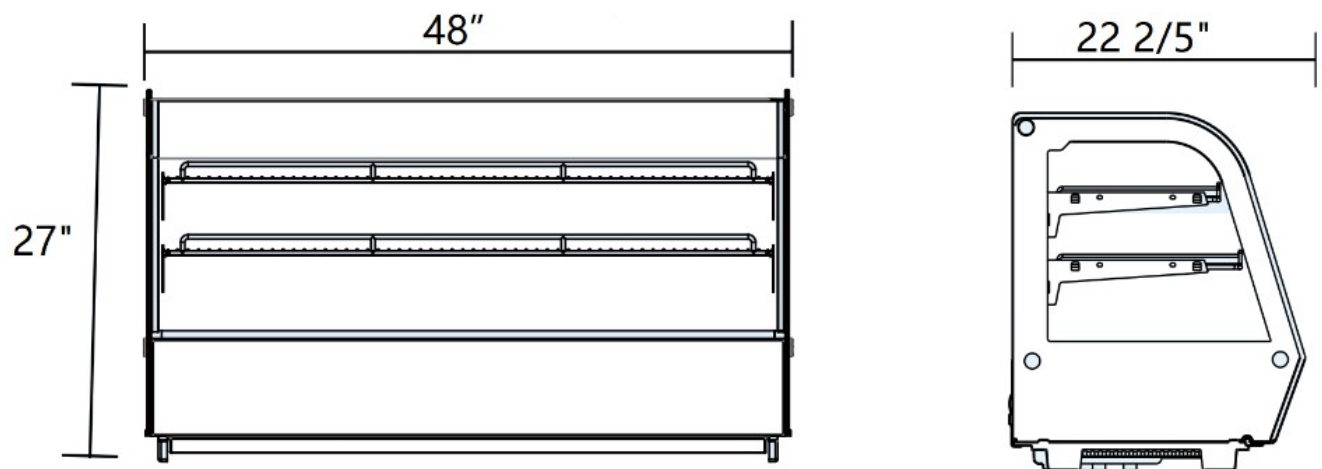

Direct Phone & Services: (516) 527-3309 . (888) 443-7014. info@unisourcefoodequipment.com . unisourcefoodequipment.com

170 Wilbur Place, Suite 300, Bohemia, New York, 11716